

Pinpoint precision Maximum efficiency



DuraScan G5

0.00025-62.5 kgf
Vickers
Knoop
Brinell

powered by
ecos Workflow™

The right device for every application.

In the load range from 0.25 gf to 62.5 kgf.



DuraScan 10 G5

- Controlled by touchscreen
- 3-fold measurement turret - manual



DuraScan 20 G5

- Controlled by touchscreen
- 3-fold measurement turret - manual
- Manual cross slide

SEMI AUTOMATIC



DuraScan 50 G5

- PC controlled
- 6-fold measurement turret - automatic
- Linear table



DuraScan 70 G5

- PC controlled
- 6-fold measurement turret - automatic
- Linear table
- Overview camera



DuraScan 80 G5

- PC controlled
- 6-fold measurement turret - automatic
- Large linear table
- Overview camera

FULLY AUTOMATIC



Vickers

According to ISO 6507, ASTM E384

HV 0,00025	HV 0,0005	HV 0,001	HV 0,002
HV 0,003	HV 0,005	HV 0,01	HV 0,025
HV 0,05	HV 0,1	HV 0,2	HV 0,3
HV 0,5	HV 1	HV 2	HV 2,5
HV 3	HV 5	HV 10	HV 20
HV 30	HV 50		

Conversion to DIN EN 50150, ISO 18265, ASTM E14005

- With optional load expansion above 0.25 gf



Knoop

According to ISO 4545, ASTM E384

HK 0,00025	HK 0,0005	HK 0,001	HK 0,002
HK 0,003	HK 0,005	HK 0,01	HK 0,025
HK 0,05	HK 0,1	HK 0,2	HK 0,3
HK 0,5	HK 1	HK 2	HK 1



Brinell

According to ISO 6506, ASTM E-10

1/1	1/2,5	1/5	1/10
1/30	2,5/6,25	2,5/31,25	2,5/62,5
5/25	5/62,5		

The DuraScan G5 series.

High-tech for your laboratory.



Force application via closed-loop control system

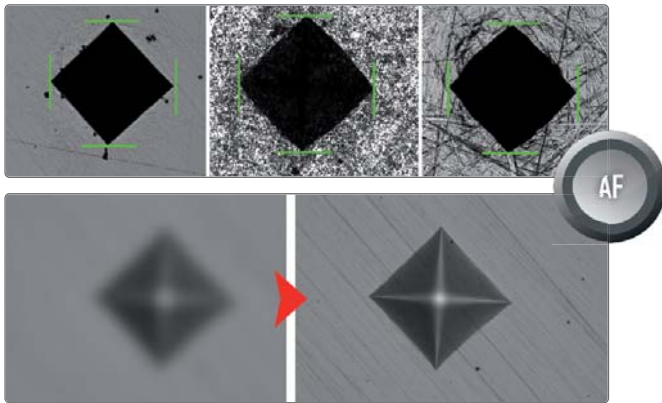

Autofocus and automatic brightness control



Patented height adjustment with rapid traverse



Precision and a broad spectrum of applications

The pioneering standard load range of the DuraScan G5 from 10 gf to 62.5 kgf expands the application range of the hardness tester enormously. This can be extended optionally to the range from 0.25 gf to 62.5 kgf – even subsequently at any time! The force is thereby continuously and precisely monitored electronically using a series of electronic force measuring sensors.



Innovation in image evaluation

The 10 Mpix camera employed in all devices of the DuraScan G5 series sets new standards in image quality. The intelligent use of the high-resolution camera chip allows a 3x zoom without having to accept any loss in quality due to interpolation. This innovative solution allows a broad range of applications to be covered with a small number of lenses. In order to make full use of this potential, the DuraScan G5 uses only lenses that offer maximum optical resolution. The proven fully automatic evaluation reliably regulates the brightness of the image and automatically evaluates the indentation.

Accelerate your processes

The innovative solutions of the DuraScan G5 series help to save time. Thanks to the new and patented rapid traverse for the height adjustment, the height of the test head can be adjusted at 10x speed. That saves precious time when adjusting to different specimen heights.

The xCHANGE interface included as standard and well documented in all DuraScan G5 devices allows the import and export of test parameters and results to be easily automated and hence accelerated.

Intuitive operating software: **ecos Workflow**

A modern and intuitive user interface shortens the familiarisation time and reduces operator errors. The **ecos Workflow** operating software developed by EMCO-TEST has been setting the standard here for years. All classic functions of hardness testing are possible here with a small number of clearly structured work steps. The operating software guides the user step-by-step through the measuring process right up to the data backup. Clear symbols and the availability of the software in 13 languages are a matter of course.

DuraScan 10 G5 and 20 G5 – semi-automatic.

Very simple operation for basic tasks.



pic.:
DuraScan 20 G5

Fast height adjustment

The proven height adjustment of the test head allows a constant and ergonomic working height. The rapid traverse helps to significantly accelerate the adjustment to different test specimen heights. The scanning function ensures automatic positioning of the test head to the perfect working distance – the camera image is immediately sharp.



260 mm test height



25 mm traverse path

Modern display

The machine is operated via a modern capacitive 10" touchscreen with brilliant image reproduction. The surface made from mineral glass is significantly more resistant to scratches than plastic surfaces.

It goes without saying that only components are employed that have been developed for use in an industrial environment.

XY table or test anvil

The basic version provides a plane anvil with all the requirements for quick and easy individual tests. The DuraScan 20 sees the series expanded to include a manual XY-cross slide enabling reliable series measurement. Optional digital spindles are also available.



test anvil DuraScan 10 G5

Important functions at a glance.

User friendliness and efficiency are of the highest priority.

Maximum working range per lens

Only lenses of the highest quality and with a large field of view are employed in the DuraScan G5. Perfect use can be made of these thanks to the use of a 10 Mpix camera. Flexible use of the camera sensor thus allows even more zoom levels per lens. The investment and tooling costs are reduced.

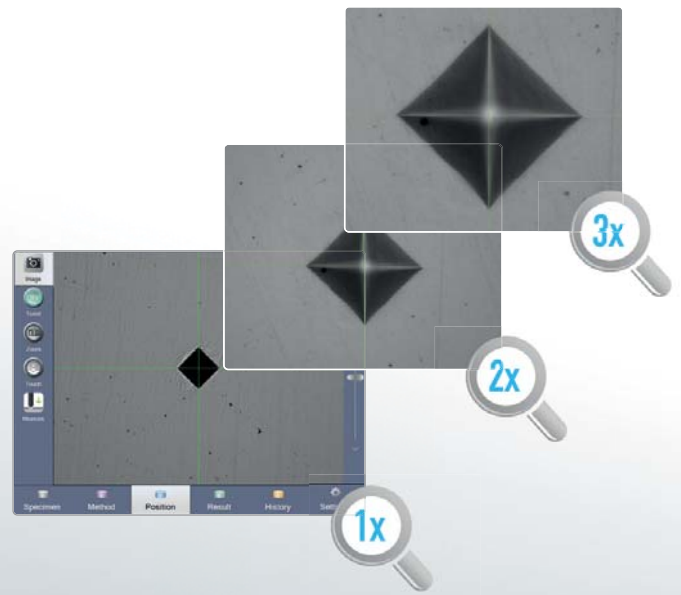

Create/load template

The use of templates significantly reduces the work for the operator and increases the safety and efficiency of the testing process. All settings for the hardness test, such as test method, lens, conversion factors, etc. can be stored as templates and loaded again whenever required. In addition, a QR code containing this information can be generated directly at the hardness tester. This can be stored e.g. as an image file and printed out on a docket, thus enabling the template data to be read in via a QR code scanner interfaced to the hardness tester.



Create template



Load template

Material and technology

The base for all machines of the DuraScan G5 series is a sturdy baseplate of high-quality granite. In combination with the legs developed by EMCO-TEST with integrated damping elements, it insulates the hardness tester against vibrations at the installation location. The frame construction of cast aluminium calculated using FEM and the high-precision linear guides guarantee precision and freedom from maintenance.

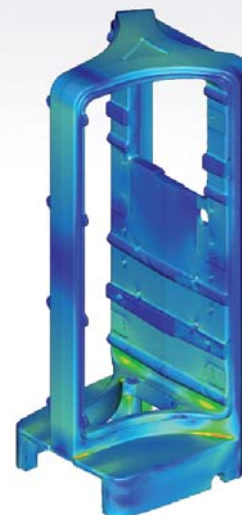

The pioneering hardness testing software.

 **ecos Workflow™ Touch.**

The workflow in five steps

Specimen, method, position, result and history are the five steps provided by the intuitive ecos Workflow operating software. Logic, transparency and very simple operation are the key factors in the workflow for efficient and convenient hardness testing. Available as standard in 13 languages.



1 Specimen

Select a type of test. On top of single measurement, from the DuraScan 20, it is also possible to conduct serial measurement, CHD, Rht or Nht runs.



2 Method

Select a measurement type, lens, test method and zoom level; and if required conversions, hardness limits and standardised device corrections.



3 Position

Position your test point on the work piece. Using the tools provided it's child's play. Then start the test.



Serial measurement

A test point wizard is available for serial, CHD, Nht or Rht testing. The wizard supports you at the creation of test point patterns when carrying out standardised serial tests (EN ISO 2639, 10328, 50190).

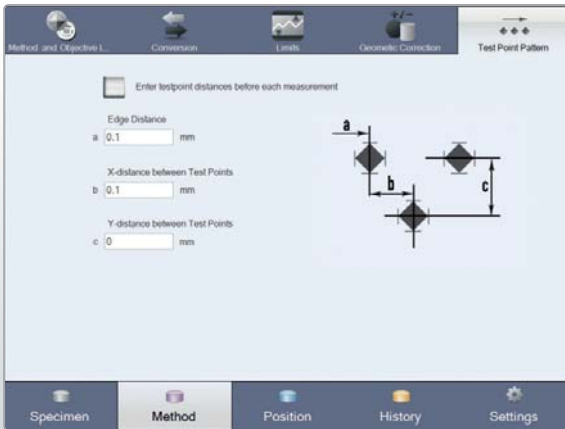

Intuitive control

Intuitive control provides an overview of which lens and indenter are currently in position. The 6-fold turret option allows selection to be made via display and mouse click.



Autofocus

Automatic test specimen height recognition triggers automatic focussing.



Figures and diagrams

Test values are converted to visuals in the form of figures or diagrams.

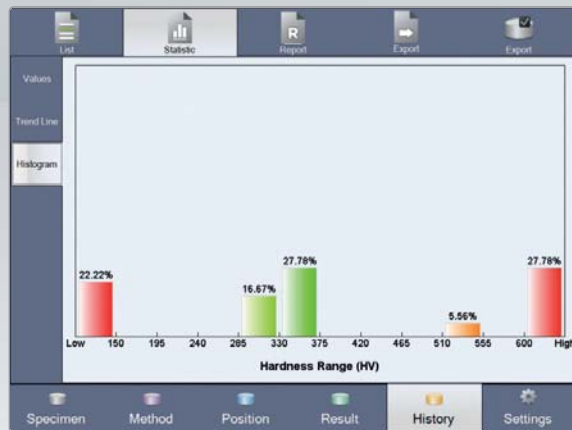

4 Result

The result is displayed clearly and is available for further uses. If necessary there is also the option of re-measuring either automatically or manually.



5 History

All results are stored permanently in a clear form. The data can be archived in your network, in other systems and used to print out a report with any installed printer.

No.	Method	Specimen	Operator	Result	Status
1	LM1	101	101	101	OK
2	LM1	102	102	102	OK
3	LM1	103	103	103	OK
4	LM1	104	104	104	OK
5	LM1	105	105	105	OK
6	LM1	106	106	106	OK
7	LM1	107	107	107	OK
8	LM1	108	108	108	OK
9	LM1	109	109	109	OK
10	LM1	110	110	110	OK
11	LM1	111	111	111	OK
12	LM1	112	112	112	OK
13	LM1	113	113	113	OK
14	LM1	114	114	114	OK
15	LM1	115	115	115	OK
16	LM1	116	116	116	OK
17	LM1	117	117	117	OK
18	LM1	118	118	118	OK
19	LM1	119	119	119	OK
20	LM1	120	120	120	OK



DuraScan 50 G5, 70 G5 and 80 G5 – fully-automatic.

Highest efficiency for complex tasks.



pic.:
DuraScan 70 G5

Innovative axes arrangement

The patented arrangement of the Z-axis as well as the Y-axis at the test head allows for a large test space and compact dimensions of the machine. Moreover, this design leads to optimal ergonomics for the user, which can be achieved thanks to the constant working height.

Highest positioning accuracy

The use of backlash-free spindles and a high digital resolution of the automatic axes enable a repeatability of under $3 \mu\text{m}$ to be achieved. The use of glass scales in the X/Y-axis enables an absolute positioning accuracy of under $0.25 \mu\text{m}$ (optional) to be achieved.

Overview camera (DuraScan 70 G5, 80 G5)

The tried and trusted overview camera ensures the perfect overview, regardless of how complicated the test procedure or the number of test points and test rows. The combination of a macro lens and a superior quality lens facilitates view ranges of 60 μm to 62 mm. This unique technology allows an overall picture of the test subject (50 x 62 mm) and clearly displays every test run. A significant simplification of the task is provided by the addition of grid, support and reference lines including a display of the possibilities for moving edges. Furthermore, the picture can also be saved in the report.

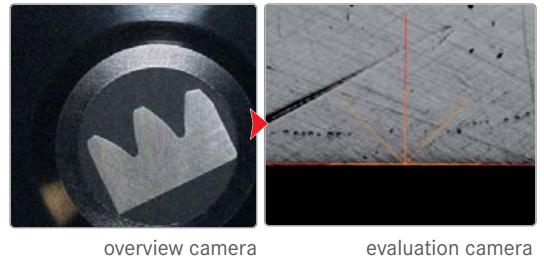

overview camera

evaluation camera

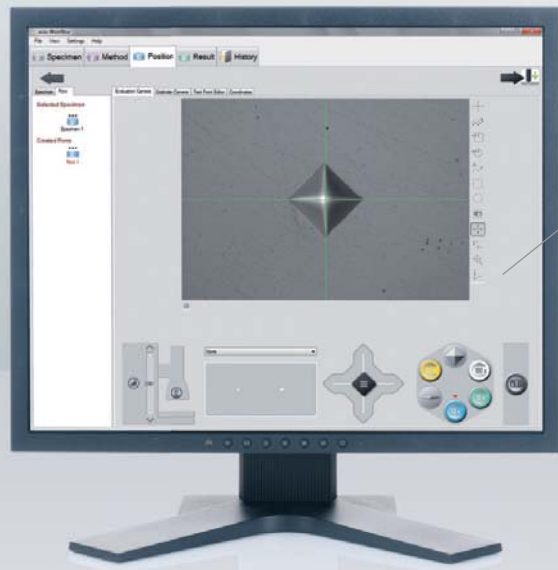

Intuitive operation

The hardness tester is controlled via the software **ecos** Workflow on an external PC.



DuraScan 80 G5 with large testing table

The DuraScan 80 G5 variant has a significantly larger test area. With the 300 mm travel distance of its X-axis, up to 12 specimens in two specimen holders can be positioned and processed at the same time. The useful working area is increased to 300 x 150 mm. The base for this device is a solid granite slab measuring 700x450 mm.

As simple as possible.



Hardness testing software that shows the way.

ecos Workflow technology shows the way ahead. Simple operation of even the most complex automation tasks is becoming increasingly important in the realm of hardness testing. The software takes over the task of directing the increasingly broad range of testing requirements and guarantees simple test object administration and lasting data security. The large proportion of software in the testing equipment allows **ecos** Workflow to make a decisive contribution to the performance capacity and quality of the overall product.



Workflow in five steps:

Specimen, method, position, result and history are the five steps of the intuitive operator software **ecos** Workflow.



Z-axis control
with autofocus

A clear overview of test magazines can be seen on the test anvil. One click on the graphic display sends the device to the correct position.

1 Specimen

Select a type of test. Single measurements, row testing, CHD, Rht and Nht are all available options.

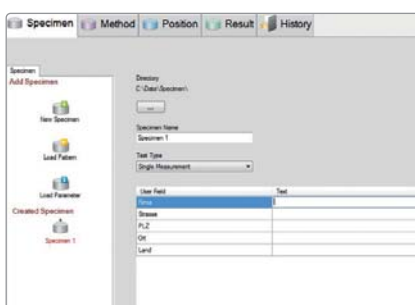

2 Method

Select a testing procedure, lens, test method and zoom level; and if required conversions, hardness limits and standardised device corrections.

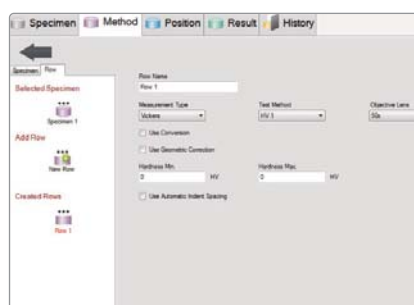

3 Position

Position your test point or line on the work piece. Using the tools provided it's child's play. Then start the test.

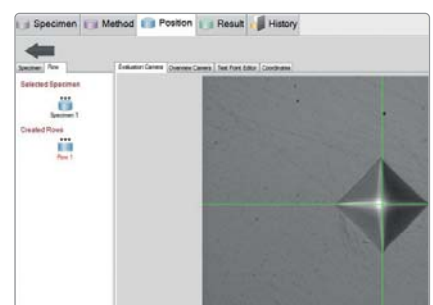

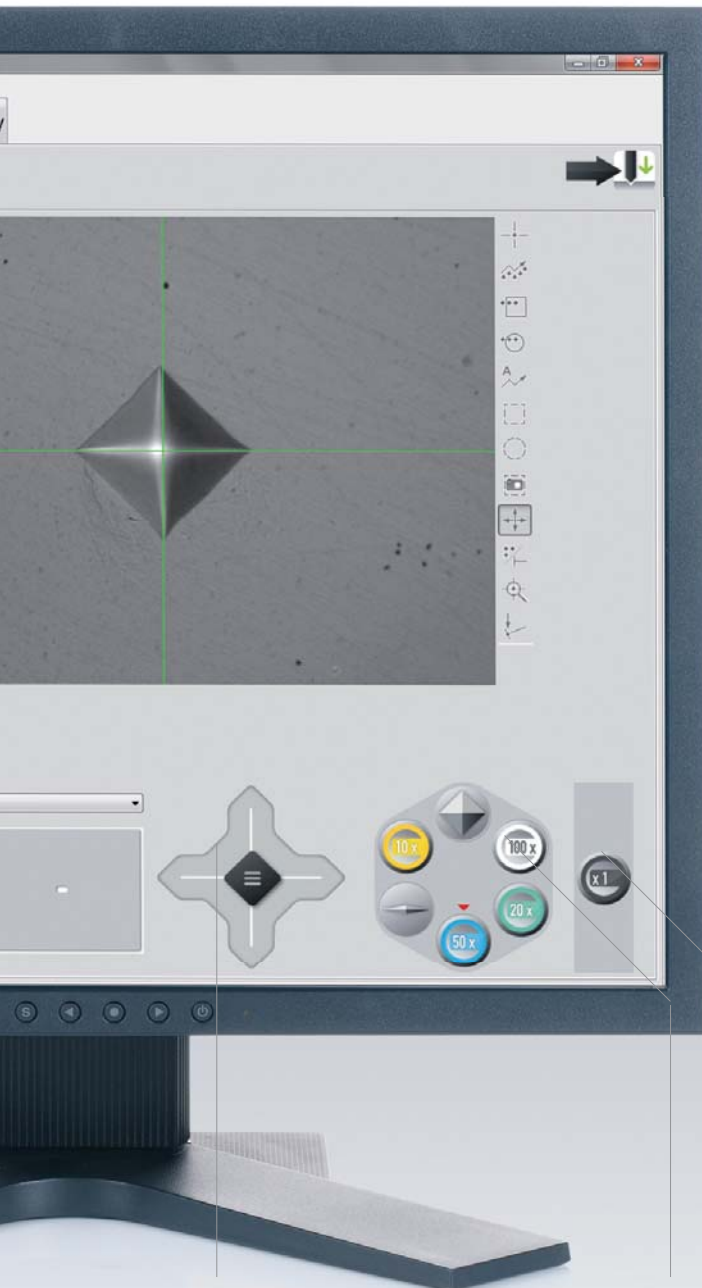

XY axis control
for positioning

6-fold measurement turret
with placement info

3-step zoom

displays the current zoom level



Single measurement

This function allows you to set individual test points wherever you like. The test measurement can be started using the surface view or the overview.



Serial measurement

One or more test rows with positioning coordinates can be recorded. The measuring process can be started in the surface view or the overview.



CHD/Nht/Rht measurement



For the performance of test series for CHD/Nht/Rht data of specimen according to standard. The test can be started directly from the surface view or from the overview. Additional core points of hardness can be defined separately for Nht measurements.

4 Result

The result is displayed clearly and is available for further uses. If necessary there is also the option of re-measuring either automatically or manually.

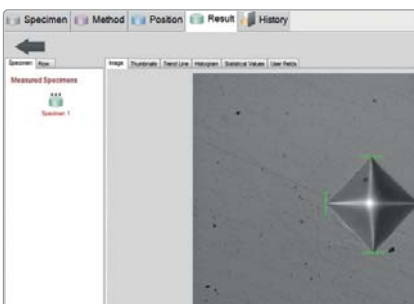

5 History

All results are stored permanently in a clear form. The data can be archived in your network, in other systems and used to print out a report with any installed printer.

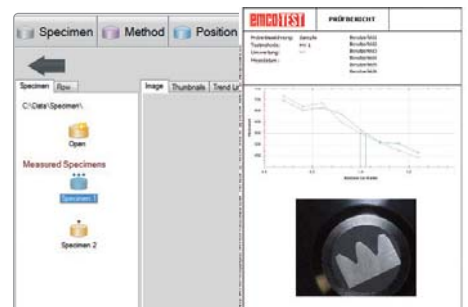
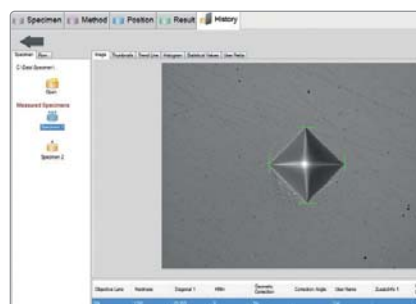

Important functions.

 **ecos Workflow Pro**: The highlights.

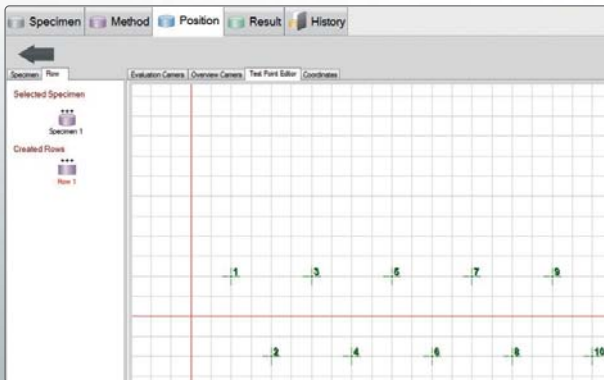

Easy generation of test series

The test point editor allows test points to be easily set up in a grid. It is also possible to set up each individual test point by entering coordinates. An even more elegant solution for serial measurement is provided by line and polygon line tools. Test series can be automatically adapted to suit work piece contours. Adherence to standard defined test distances (i.e. point distance = 3 x diagonal) can also be done with the integrated tool.

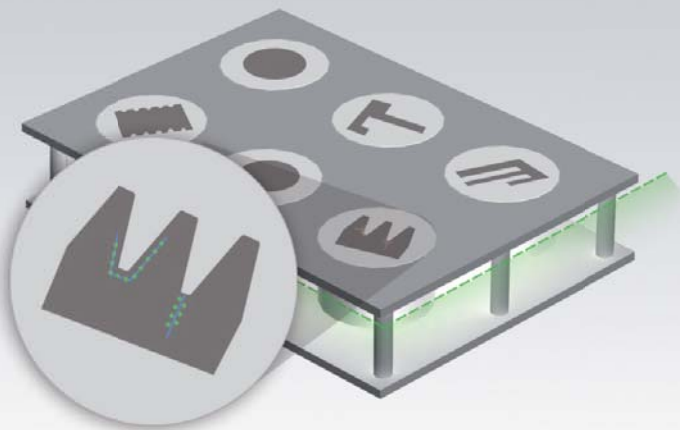

Single and multiple test samples

The standard version allows the specimen to be set up for several test series and be measured automatically. The functions required for this are clearly visible in a tool list. An optionally available software module 'ecos Workflow multiple specimen' allows several specimen (i.e. 12 bedded specimen in two 6-fold-sample holders) each with several test series to be tested fully automatically.

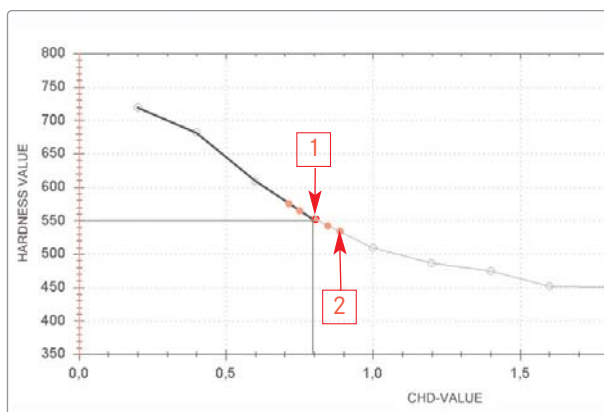

Optimise CHD serial testing

To ensure a maximum of accuracy with reduced testing time i.e. when determining hardness penetration depth (CHD, Nht, Rht), two features have been made standard for the software:

1. Automatic stop on reaching hardness limit

The limit is defined and the number of measuring is provided when the limit is reached. It is not necessary to know in advance how many indentations have to be made until the CHD is reached.

2. Subsequent addition of test points

The CHD value determined by the hardness threshold can be determined more accurately the more test points have been set up in this range. Subsequent insertion of test points around the established CHD value allows the provision of a more accurate result within a shorter test time frame.

Positioning with panorama function

The macro lens is designed for 50 x 62 mm test specimen size. This allows for the simple and transparent positioning of the test points and test series in real time. Moreover, the panorama function also allows larger test specimen to be completely included in the setting of test points. Specimen size is only limited by the movement distance of the slide. Specimen pictures for archives and records are set up for a 50 x 62 mm format.

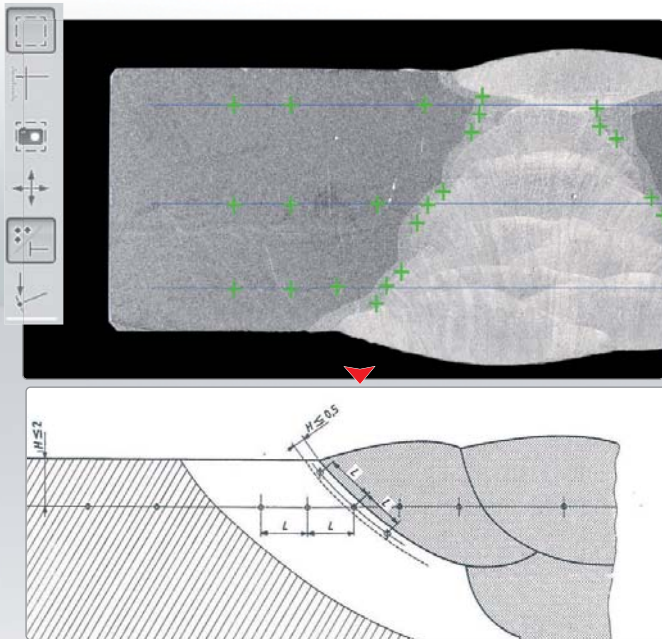

The overview camera provides a panoramic overview of the work piece (variations DuraScan 70 G5 and 80 G5).

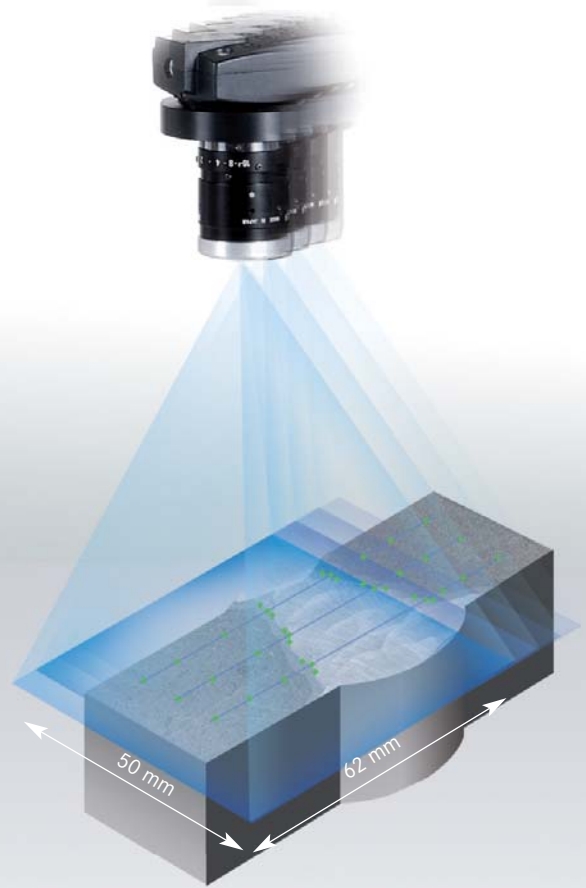

Time saving pattern mode

Specimen that have already been measured are used as a guideline containing certain elements and basic settings for new specimen. The settings from the basic guideline are automatically used for new specimen. Guidelines are automatically generated for each measurement and archived specimen. Operators are recommended to use guideline settings when testing a series of identical parts, or when frequently testing parts that always conform to certain parameters, tolerance levels, test methods etc., or continually exhibit the same pattern of test results, but have varying descriptions. Conduct complex testing tasks with very few clicks.

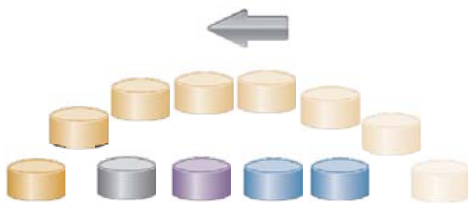

Already measured specimen can be used as templates for new measurements

The rotation axis positions the test pattern on the work piece.

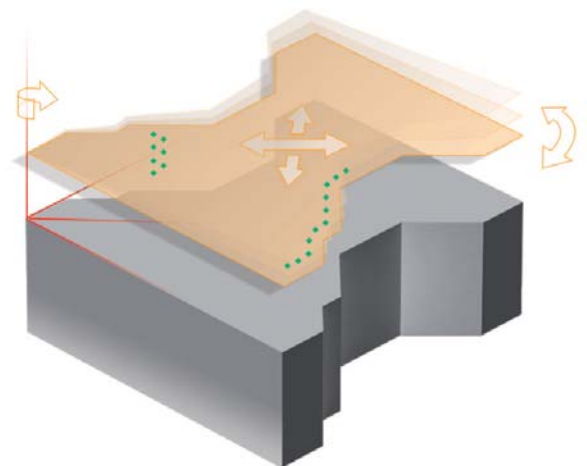

Modern data management with ecos Workflow.

Simple and safe handling of data.



Efficient data management

The vast number of measured values created during the course of comprehensive quality assurance demands highest levels of precision and availability from computerised QA systems.

In order to guarantee continuous documentation and reliable allocation of measured data to the respective workpiece, all DuraScan G5 models offer extensive possibilities for data output and backup.

In addition to storing of the test results directly at the hardness tester, all the data collected during the test can also be saved as files in .pdf, .xls (Excel) or .xml format. The output in .xml file format allows simple interfacing to Q-DAS systems. The integrated **Export Editor** offers extensive adaptation possibilities. In addition to the scope and sequence of the exported measurement data, a new file can also be generated automatically after each measurement, thus significantly simplifying the automatic further processing.

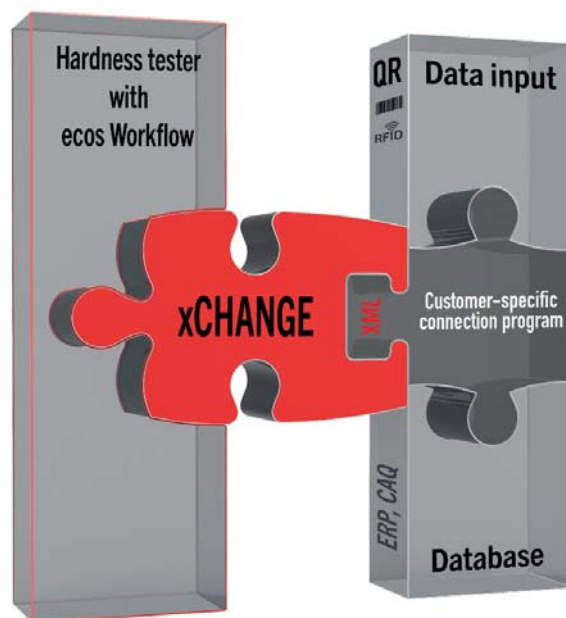

ecos Workflow xCHANGE

The xChange interface forms part of the standard configuration of all hardness testers of the DuraScan and DuraVision Series. This facilitates implementation of practically all customer-specific requirements for connecting the hardness tester to databases and data input devices, as well as fully automatic or unmanned operation. Since ecos Workflow xCHANGE is based on the established XML format, interaction with it is simple and structured.



Create customized test reports

All DuraScan models come standard with the 'direct print' function. This function allows you to make an immediate print-out of a test report on a printer connected to the system. For the DuraScan models 70 and 80 the overview camera enables you to integrate also a picture of the specimen (see example below). Moreover, the flexible and convenient form and report generator provides the possibility to generate easily customized reports for the documentation of test results.

Inclusion of your corporate logo on the test report

Individual spaces for specimen description and test parameters

Macro-view of specimen picture with test point labelling (only possible with overview camera)

EMCO TEST Report

Seriesname: Sample 3
 Testmethod: HV 1
 Conversion: ---

Userfield 1:
 Userfield 2:

Userfield 3:
 Userfield 4:
 Userfield 5:
 Userfield 6:
 Userfield 7:
 Userfield 8:
 Userfield 9:
 Userfield 10:

Measured with EMCO TEST Hardtest v. EMCO TEST Prüfmaschinen GmbH - 5431 Kochl - 10 - +43 (0)4 24 20038-20 - e) info@emcotest.com

Härtewert

Abstand zur Kante

Date: _____ Signature: _____

Other freely definable fields

Progression curves



Space for results tables, statistics etc.

Specimen	Row	Testpoint	Hardness	Method	Lens	X-distance to start point
Specimen 1	Row 1	1	716	HV1	50x	0,200
		2	668	HV1	50x	0,400
		3	684	HV1	50x	0,600
		4	599	HV1	50x	0,800
		5	549	HV1	50x	1,000
		6	716	HV1	50x	1,200
		7	668	HV1	50x	1,400
		8	684	HV1	50x	1,600
		9	599	HV1	50x	1,800
		10	549	HV1	50x	2,000

Options.

Adapt the DuraScan G5 to your needs.



Optional load range from 0.25 gf

On all DuraScan G5 hardness testers, the total test load per indenter can be optionally extended to the range from 0.25 gf to 62.5 kgf. The load range below 10 g makes high technical demands on the design of the hardness tester as far as the accuracy of the application of these small forces is concerned. All DuraScan G5 devices therefore have a solid granite slab as base and legs with damping elements specially designed for the DuraScan G5 Series. These reduce the vibrations acting on the device by 50% compared with legs with conventional rubber dampers. In addition, EMCO-TEST provides precise information on the demands on the installation location with respect to vibrations.

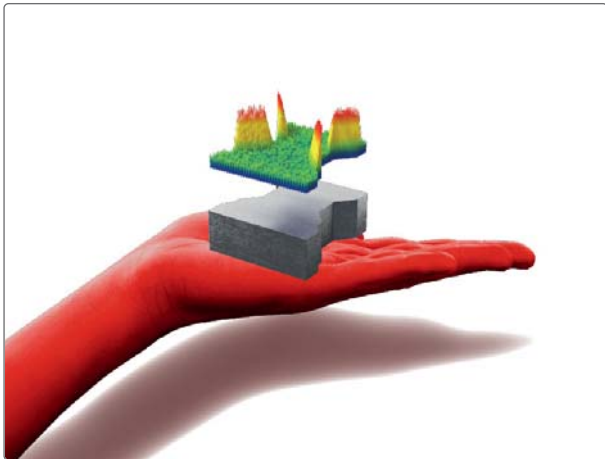

areaMaster

This software module is your convenient assistant when it comes to automated solutions for complex hardness testing tasks. It supports laboratory users wishing to position a large number of test points on a defined surface or along the edge of the specimen.

The integrated hardness map – a colour display of the hardness distribution on surfaces – ensures the optimum visualisation of your results. Even large volumes of information, such as hardness values and coordinates of the test points, are shown clearly because logic, transparency and very simple operation are hallmarks of all software developments from EMCO-TEST. The areaMASTER is integrated into the ecos Workflow operating software and guarantees ease of operation as well as offering extensive export possibilities. The software module is available for the EMCO-TEST devices DuraScan 50,70 and 80 G5.



Ring light

Optimum illumination of difficult surfaces: Particularly for Brinell tests on soft metals or poor specimen surfaces, use of the powerful LED circular light ensures even better detectability of the test indent. For use with the lenses 2.5x, 4x and 10x. Quickly installed: The circular light can be installed and removed again very quickly. Installation itself is child's play.

What you need.

Indenters and lenses for your application range.

Indenters

EMCO-TEST offers a whole range of indenters. All certified indenters comply with international standards according to EN ISO or ASTM. Select the correct indenter for your tests.



Lenses

Principally, the smaller the test load required - the greater the degree of magnification. A wide range of lenses you can find in our accessories catalogue.



Set-up assistant

The set-up assistant helps to configure your hardness tester. It guides you through the most important settings such as upgrades, add-ons and exchange of lenses and indenters.

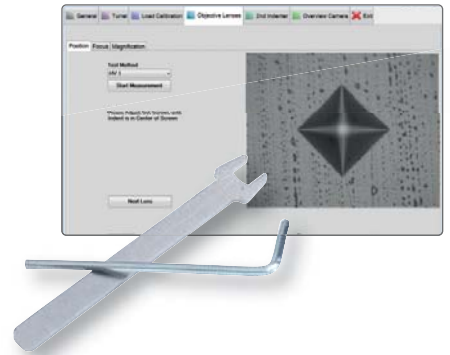

Complete accessories catalogue at www.emcotest.com

Go to www.emcotest.com for the entire range of accessories for the DuraScan hardness testing machine, including the complete range of indenters (incl. certificate acc. to EN ISO/ASTM), special test anvils, adapters for additional indenters, lenses, etc.



Digital micrometer spindle
(optional for DuraScan 20)



Machine vice



Manual chuck



1-fold specimen holder



6-fold specimen holder



Test blocks

360° FULL SERVICE COMPETENCE

Competence and experience – hand-in-hand.



Our strategy

With the vision of building machines that don't simply do everything, but do everything simply, Ernst Alexander Maier developed EMCO-TEST from the inheritance of his father and company founder into the world technology leader in the field of hardness testing. Today we are the largest manufacturer of hardness testing machines with the most modern and most efficient technologies in Europe. True to our mission of making everything to do with hardness testing

simpler, we offer comprehensive solutions for all these tasks from a single source: Development, production, calibration, consultation and supplementary services – complete coverage of all important issues. This means competence in all aspects of hardness testing: **360° FULL SERVICE COMPETENCE.**

Accredited calibration laboratory to ISO 17025

In order to comply with international standards, for reproducibility of measurement results and for comprehensive documentation of the test cycles, EMCO-TEST offers accredited calibration in accordance with EN ISO / IEC 17025:2007. Our accredited calibration laboratory ensures that the services offered always represent the state-of-the-art of the standards and technology.

Premium quality with certified quality promise (ISO 9001)

In order to ensure that only perfect quality is supplied to you, every EMCO-TEST testing machine is thoroughly and stringently tested before delivery. The ease of service is taken into consideration right from the beginning in the design phase. The results are menu-driven fault detection, integrated self-diagnosis and modular exchange of electronic components that ensure the remedying of faults in a minimum of time. Software updates that take into consideration changes in standards or optimise future processes ensure high investment security for you.

Service App

With the EMCO-TEST Service app, you can quickly and easily send a service message around the clock and from anywhere in the world. The app guides you step-by-step in easily creating your service message. This ensures that our service technicians receive all the relevant data on the machine and can quickly provide assistance in an emergency. These and many other functions await you in our EMCO-TEST Service app.

Remote Support

The TeamViewer Client integrated as standard can be started directly from ecos Workflow and offers the optimum basis for perfect online support worldwide. This software allows remote maintenance as well as the sharing of the screen contents with other computers, e.g. for training purposes (internet connection required).



Technical data – DuraScan 10 G5 and 20 G5



DuraScan 10 G5

SEMI-AUTOMATIC

Methods and load range	
Load range 0.098 - 612.9 N (0.01 - 62.5 kgf) - electronically controlled	•
Load range 0.002452 - 612.9 N (0.00025 - 62.5 kg) - electronically controlled	optional (per indenter)
Vickers (ISO 6507, ASTM E384)	•
Knoop (ISO 4545, ASTM E384)	•
Brinell (ISO 6506, ASTM E10)	•
Configuration	
10" capacity colour display (800x600 pixels), tiltable	•
ecos Workflow operating software touch	•
Automatic test cycle with brightness control and evaluation	•
3x Zoom	•
10 Mpix evaluation camera with CMOS sensor	•
Baseplate of polished granite	•
Legs with integrated damping elements	•
Machine control via integrated PLC	•
Motorised height adjustment of the test unit with rapid traverse	•
Manual 3x measuring turret	•
Automatic 6x measuring turret	optional
Ring light	optional
Test table	Ø 90 mm
Manual cross table with 25 mm travel distance and analogue micrometer spindles	optional
Manual cross table with 50mm travel distance and analogue micrometer spindles	optional
Digital micrometer spindles	optional
Operating system Windows 7 / 64 bit	•
Operating system Windows 7 / 32 bit	optional
Software functions	
Module for serial measurements	optional
Template function	•
QR code function	•
Extended export functions via Export Editor	•
ecos Workflow xCHANGE (XML-based interface for data links)	•
Integrated TeamViewer client	•
Interfaces	
Network interface	RJ45
USB interface	2x
RS 232 interface	1x
VGA interface	•
Integrated memory (SSD)	32GB



DuraScan 20 G5

•
optional (per indenter)
•
•
•
•
•
•
•
•
•
•
•
•
optional
optional
135 mm x 135 mm
•
optional
optional
•
optional
•
•
•
•
•
•
RJ45
2x
1x
•
32GB

Functional dimensions:

Space requirement (WxD)	700 x 600 (mm)
Max. workpiece weight	50 kg
Positioning accuracy with manual spindles	0,1 mm
Test force application resolution	24 bit
Max. test height	260 mm
Z-axis resolution	2,6 nm
Max. speed on Z-axis	1,2 mm/sec. bis 25 mm/sec.

Machine data:

Weight of basic unit	85 kg
Dimensions (WxHxD)	550 x 700 x 450 (mm)
Protection class to EN 60529	IP20
Power consumption (max. / standby)	120 W / 50 W
Max. voltage fluctuations	± 10%
Main fuse (110 / 230V)	T6,3A
Room temperature (to ISO/ASTM)	23 (± 5)°C
Humidity	max. 70% (non-condensing)

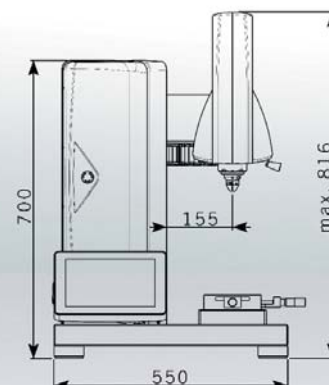

Technical data – DuraScan 50 G5, 70 G5 and 80 G5



DuraScan 50 G5

FULLY-AUTOMATIC

Methods and load range		
Load range 0.098 - 612.9 N (0.01 - 62.5 kgf) - electronically controlled		•
Load range 0.002452 - 612.9 N (0.00025 - 62.5 kgf) - electronically controlled		optional (per indenter)
Vickers (ISO 6507, ASTM E384)		•
Knoop (ISO 4545, ASTM E384)		•
Brinell (ISO 6506, ASTM E10)		•
Configuration		
Fully automated linear tables for positioning of the specimens		•
ecos Workflow operating software (for Windows 7, Windows 8, Windows 10)		•
Control via interfaced PC system		•
Automatic test cycle with brightness control and evaluation		•
3x Zoom		•
10 Mpix evaluation camera with CMOS sensor		•
Baseplate of polished granite		•
Legs with integrated damping elements		•
Machine control via integrated PLC		•
Motorised height adjustment of the test unit with rapid traverse		•
Automatic 6x measuring turret		•
Overview camera for panorama function in real-time		-
Ring light		optional
Test table (WxL)		150 x 200 mm
Travel distances of the axes (X / Y)		150 x 150 mm
Glass scales for X-Y axes to increase the absolute positioning accuracy to < 1 µm		optional
Software functions		
Template mode		•
CHD, NHD, SHD and serial measurements		•
Extended export functions via Export Editor		•
ecos Workflow xCHANGE (XML-based interface for data links)		•
Multiple specimen module for testing several specimens in one work cycle		optional
areaMASTER software module for generation of hardness maps		optional
Integrated TeamViewer client		•
Interfaces		
Interfaces for PC connection		1 x USB 2.0 1x RJ45



DuraScan 70 G5



DuraScan 80 G5

•	•
optional (per indenter)	optional (per indenter)
•	•
•	•
•	•
•	•
•	•
•	•
•	•
•	•
•	•
•	•
•	•
•	•
•	•
•	•
•	•
•	•
•	•
•	•
optional	optional
150 x 200 mm	150 x 300 mm
150 x 150 mm	300 x 150 mm
optional	optional
•	•
•	•
•	•
•	•
optional	optional
optional	optional
•	•
2 x USB 2.0 1x RJ45	2 x USB 2.0 1x RJ45

Functional dimensions:

Space requirement (WxD) DuraScan 50 G5/70 G5	700 x 600 (mm)
Space requirement (WxD) DuraScan 80	850 x 600 (mm)
Max. workpiece weight	50 kg
Positioning accuracy	0,0035 mm
Positioning accuracy with glass scale	<0,001 mm
Test force application resolution	24 bit
Max. test height	260 mm
Z-axis resolution	2,6 nm
Max. speed on Z-axis	1,2 mm/sec. bis 25 mm/sec.

Machine data:

Weight of basic unit (DuraScan 50 G5/70 G5)	87 kg
Weight of basic unit (DuraScan 80 G5)	98 kg
Dimensions (WxHxD) DuraScan 50 G5/70G5	550 x 700 x 450 (mm)
Dimensions (WxHxD) DuraScan 80 G5	700 x 700 x 450 (mm)
Protection class to EN 60529	IP20
Power consumption (max. / standby)	120 W / 50 W
Max. voltage fluctuations	± 10%
Main fuse (110 / 230V)	T6,3A
Room temperature (to ISO/ASTM)	23 (± 5)°C

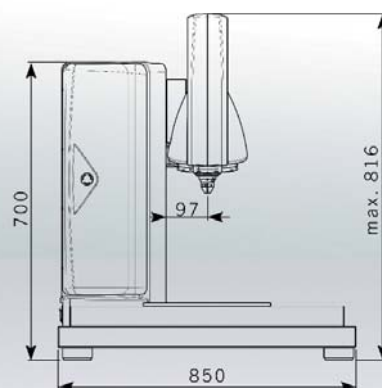

Benefit from our global sales and service network!

With qualified sales and service partners in over 40 countries, we guarantee top level support for you and your machine. You can find your local dealer on our website www.emcotest.com.



- Austrian head office
- Sales and distribution partners

EMCO-TEST

YOUR FACTOR OF SAFETY

EMCO-TEST (Deutschland) GmbH

Frühlingstraße 6

83278 Traunstein

office@emcotest.de

Tel. +800 20 438 000

www.emcotest.de

EMCO-TEST Prüfmaschinen GmbH

Kellau 174

5431 Kuchl-Salzburg/Austria

office@emcotest.com

Tel. +43 6244 204 38

www.emcotest.com

Fax +43 6244 204 38-8



**made in
Austria**

